

This white paper gives answers to:

- [What is COOLPULSE Technology?](#)
- [What is AFM Technology?](#)
- [How do these technologies enable smooth surfaces?](#)

Smooth Surfaces for Additive Manufacturing

By
*Robert Binder,
Product Manager at Extrude Hone
Lukas Fuchs, Business Development Manager
Turbomachinery at EOS GmbH*

Extrude Hone's Coolpulse and AFM enable cost-effective surface finishes

During application development, it is often the case that Additive Manufacturing (AM) and surface finishing processes are considered separately and sequentially. This leads to suboptimal results in terms of final surface finish and increased cost per part (CPP). Consequently, it is necessary to consider AM and surface finishing during the design phase which entails designing

both for AM build and surface finishing simultaneously as well as defining the right combination of technologies. Extrude Hone and EOS are the perfect partners to support this task. They are both market leaders in their fields having jointly conducted successful case studies. This article describes three cases that illustrate the above challenges and how they were met.



Content

Executive Summary	1
Introduction	3
Understanding How it Works	4
Case Studies	6
Case 1 Swirler in Inconel 718	6
Case 2 Valve Block in Ti6-4	10
Case 3 Surface test sample 17-4PH stainless steel	14
Conclusion	19
Contact	20

List of figures

Figure 1	Working principle AFM	4
Figure 2	Principle of anodic metal dissolution	5
Figure 3	Overview of processed parts with different processes	6
Figure 4	3D scans of Swirler blades	7
Figure 5	Surface structure on blade under the microscope	8
Figure 6	COOLPULSE tooling apart	9
Figure 7	COOLPULSE tooling assembled	9
Figure 8	Valve Block Cutaway (incoming condition)	10
Figure 9	Valve block cutaway (after finishing)	11
Figure 10	COOPULSE tooling main bore & base	12
Figure 11	COOLPULSE tooling showing cathode and part	12
Figure 12	Close-up of side channel finished with AFM	13
Figure 13	AFM tooling	13
Figure 14	Before / after image of the part	14
Figure 15	Lab test tooling	15
Figure 16	Different layer thicknesses	16
Figure 17	Measurement path	16
Figure 18	Material Removal Graph	17
Figure 19	Sample parts after COOLPULSE starting with different surface roughness after AM	18

Introduction

During application development, it is often the case that Additive Manufacturing and Surface Finishing processes are considered separately and sequentially. This leads to suboptimal results in terms of final surface finish and increased cost per part (CPP).

Between AM and surface finishing there is a multitude of possible combinations (e.g. selection of AM layer thickness, selection of AM process, selection of right surface finishing combination, selection of right surface finishing parameter) that heavily influence final part quality and CPP.

In most cases, the know-how to select the right combination is not available leading to an empirical approach creating the need to perform several test jobs.

These two challenges result in many cases being rejected, because CPP or surface requirements are not met or because the development phase was too resource-intensive.

Consequently, it is necessary to consider AM and surface finishing during the design phase which entails designing both for AM build and surface finishing simultaneously as well as defining the right combination of technologies. Extrude Hone and EOS are the perfect partners to support this task. They are both market leaders in their fields having jointly conducted successful case studies. This article describes three cases that illustrate the above challenges.

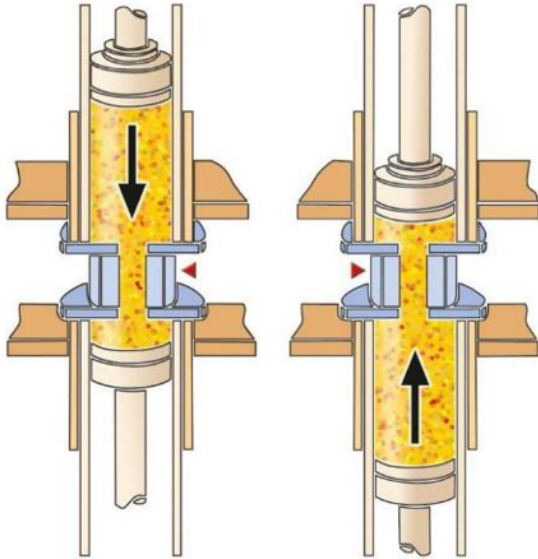

Figure 1 - Working principle AFM

Understanding How it Works

In the following short introduction to our processes Abrasive Flow Machining (AFM) and COOLPULSE we want to give you the basic information you need to understand our processes, and to empower you to understand the relations between the different outcomes of the cases and what value each process can add to your 3D printed metal parts.

Abrasive Flow Machining (AFM) uses a chemically inactive and non-corrosive media, to improve the surface finish and edge conditions of your parts. The abrasive particles in the media grind away rather than shear off the unwanted material. The rate of material removal depends on the factors as media flow rate, viscosity, abrasive particle size, abrasive concentration, particle density, particle hardness and workpiece hardness.

The AFM process controls the media flow rate and pressure, volume and type of media, media temperature, and consequently the amount of material that is removed. For any given application, the material removal rate per unit of volume can be determined and monitored to ensure repeatability. The same type of media can be used on different metals. In many cases, the same batch of media can be used on different metals without transferring removed material between different workpieces.

Figure 1 shows the working principle of an AFM machine. We have a fixture, which accommodates the parts and controls the media flow path through the part, which is placed between two hydraulic cylinders. Before the fixture is being placed the media, which is required for the processing is inserted in the bottom cylinder chamber. After placing the fixture is being clamped in between the two cylinders and sealed, so no media can leave the fixture while processing. After applying the right pressure, the process starts. In figure 1 we show a two-way flow AFM process which means, that the two cylinders press the media through the workpiece. This is an automated process with the two cylinders alternating between upward and downward movement.

COOLPULSE (CP) falls under the category of the Anodic Metal Dissolution Technologies, similar to Electro Chemical Machining (ECM). The component is machined by utilizing tool that mimics the surface geometry of the 3D printed component. The printed part is connected to a positive electric pole (anode), and the printed tool is connected to a negative electric pole (cathode). The surface of the printed part is machined by running an electrolytic solution between the parts, while driving a controlled DC current between the part and the tool.

Figure 2 describes the basic working principle of ECM technologies. The workpiece is being connected to the PLUS pole (anode) of a DC current supply (generator) and the tooling is being connected to the MINUS pole (cathode). Both, workpiece and tooling, are separated of each other by a working gap of approx. 3 – 5 mm. This gap is being flushed with conductive electrolyte which transports the removed material out of the working area and ensures load transfer between the two poles.

Extrude Hone categorizes the applications in two different modes. One is called "Bath" technology, where very simple cathodes can be used, but the machining is limited to deburring and finishing applications on external surfaces and cavities with an aspect ratio < 0.5 , and "Tooling" technology, where a part specific tooling ensures uniform and high-class surface finishing on external, as well as on internal surfaces.

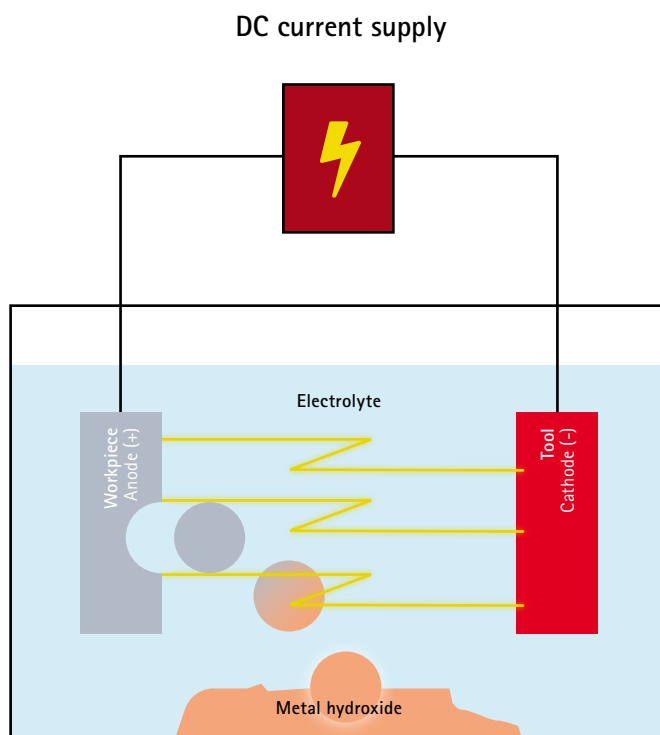

Figure 2 - Principle of anodic metal dissolution

Case 1

Swirler in Inconel 718

Application data:

- **Printing:** EOS M 290 with EOS NickelAlloy IN718 material and IN718 Performance (40µm) process
- **Post-3D:** Support removal
- **Task:** Surface finish of the internal vane section and external surfaces

Case Study:

Figure 3 gives an overview about the results of three different processes used for surface finishing of a metal 3D printed part made of Inconel 718. COOLPULSE, AFM and a combination of both processes where COOLPULSE was used externally to achieve a Ra of 1.6 µm on the downskin surface and as pre-finishing process to AFM process for polishing of the vanes on the inside of the part.

AM (reference)	COOLPULSE	AFM	COOLPULSE & AFM
Ra blade: 5 – 8 µm	Ra blade: 0.6 µm	Ra blade: 0.18 µm	Ra blade: 0.19 µm
Ra external: 5 – 12 µm	Ra external: 1.6 µm		Ra external: 1.6 µm
	Process Time: 23 min	Process Time: 54 min	Process Time: 50 min
	Removal: 130 µm	Removal: 80 µm	Removal: 125 µm

Figure 3 – Overview of processed parts with different processes

AM (reference)

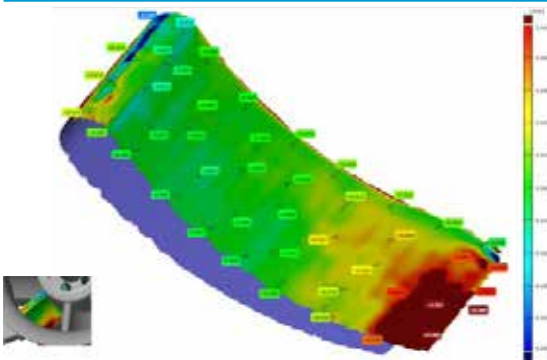

COOLPULSE

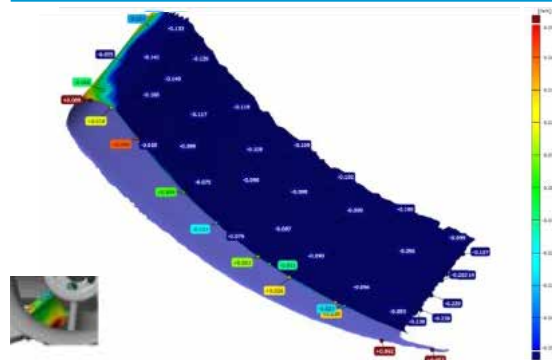

AFM

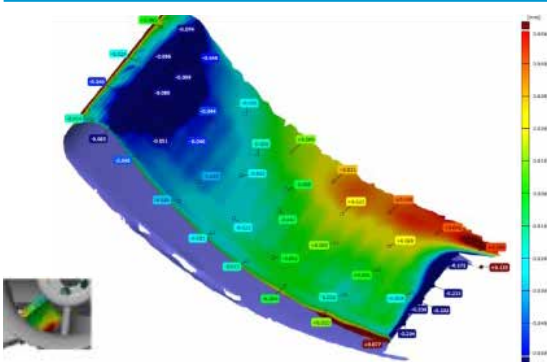

COOLPULSE & AFM

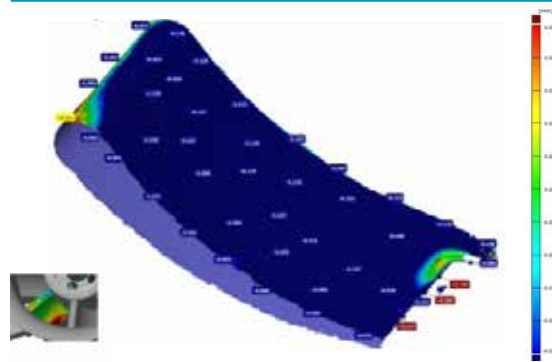
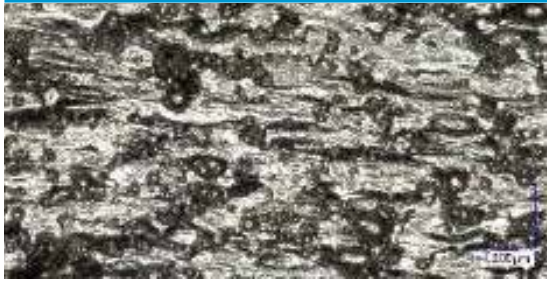

Figure 4 – 3D scans of Swirler blades

The 3D scans which you see in figure 4 illustrate the impact of each process on geometrical and dimensional accuracy. They also demonstrate the limitations of each process with regards to uniformity of the results. This is carried out by comparing the scanned geometry of the finished part with the 3D model. The color shows the amount of deviation at different measuring points.

Figure 5 shows the surface structure under a magnification of 200x under the microscope. All shots were taken from the surface of the internal blades. You can clearly see the rough surface of the printed parts. The photo taken from part only processed with COOLPULSE shows a smooth surface, without pores, but with a remaining waviness. AFM shows a typical surface structure of an abrasive process, but still having remaining pores, because the material removal was not enough to completely remove it from the surface. The surface produced with COOLPULSE and AFM shows a fine polished surface without any pores.

AM (reference)

- rough surface structure
- high waviness
- cavities and pores

COOLPULSE

- smooth surface finish
- remaining waviness
- score-wfree surface
- isotropic surface finish

AFM

- typical scoring for abrasive technologies
- remaining cavities

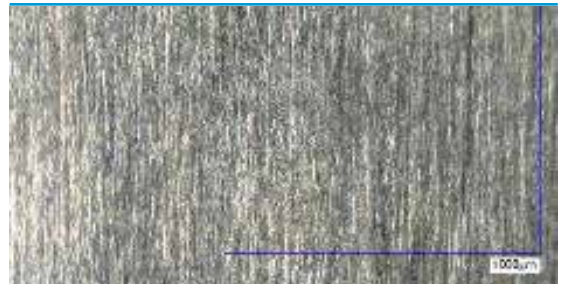
COOLPULSE & AFM

- typical scoring for abrasive technologies
- NO remaining cavities

Figure 5 - Surface structure on blade under the microscope



Figure 6 - COOLPULSE tooling apart



Figure 7 - COOLPULSE tooling assembled

In figure 6 and 7 you can see the tooling for the test part Swirler, assembled and disassembled. The tabs on the right and left side are used for contacting the cathode to the minus pole of the machine base plate. The electrolyte is supplied from the bottom and leaves the fixture through the bores in the top plate.

Summary:

All three surface finishing process types, COOLPULSE, AFM, and COOLPULSE & AFM, have their benefits. COOLPULSE produces high material removal rates, high form accuracy, and allows simultaneous surface finishing on the internal and external surfaces. AFM instead delivers high-quality surface finish with less stock removal. Combining both technologies, COOLPULSE and AFM one after the other provide a very uniform and high-end surface. The combination was used on the internal surface whilst COOLPULSE only was used for the external surfaces.

Case 2

Valve Block in Ti6-4

Application data:

- **Printing:** EOS M 290 with EOS Titanium Ti64 material and Ti64 Performance (30 μ m) process
- **Post-3D:** No post AM process
- **Task:** Main bore surface enhancement done with COOLPULSE and side channel processed with AFM.

Figure 8 shows the part Valve Block as built on the 3D printer. It was optimized to minimize the need for support structure to limit post-treatment after 3D printing. But this is not all, it was also optimized to maximize the AM freedom of design, including weight-saving, optimization of flow conditions, and improvement of mechanical strength in highly stressed areas.

The average Ra of surface roughness measured on the internal and external surfaces was 10 μ m. To maintain geometrical tolerances, the required overstock for COOLPULSE finishing was already added during the design stage. In addition, tabs for the anodic contact were added to the part before printing.

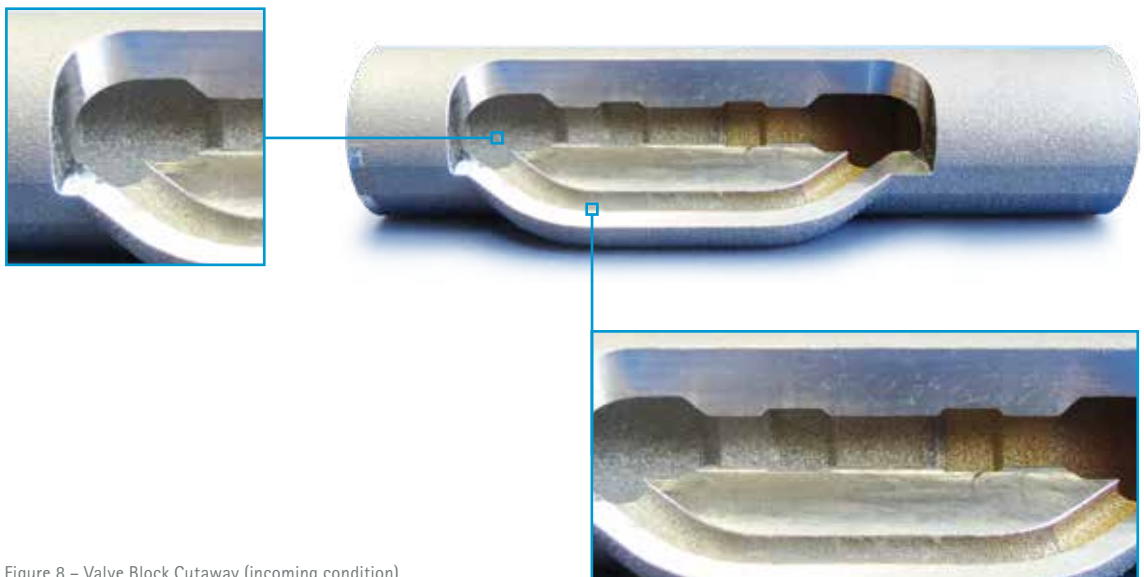

Figure 8 – Valve Block Cutaway (incoming condition)

The biggest challenge on this application was to differentiate the finishing of the main bore section, which acts as the valve seat, from that of the side channel. We could not use AFM on the main bore due to the step changes in diameter along the length. This would prevent the AFM media to apply the required cutting force uniformly to the surface to achieve a uniform surface finish. With COOLPULSE, however, it was possible to complete the task without using very complicated and expensive process steps and tooling.

COOLPULSE was able to improve the surface roughness from Ra 10 μm to Ra 2 μm .

A cycle time of 40 minutes was achieved by simultaneously finishing internal and external features. In figure 9 shows the part finished in the main bore and on the outside with COOLPULSE, while the side channel was finished using AFM.

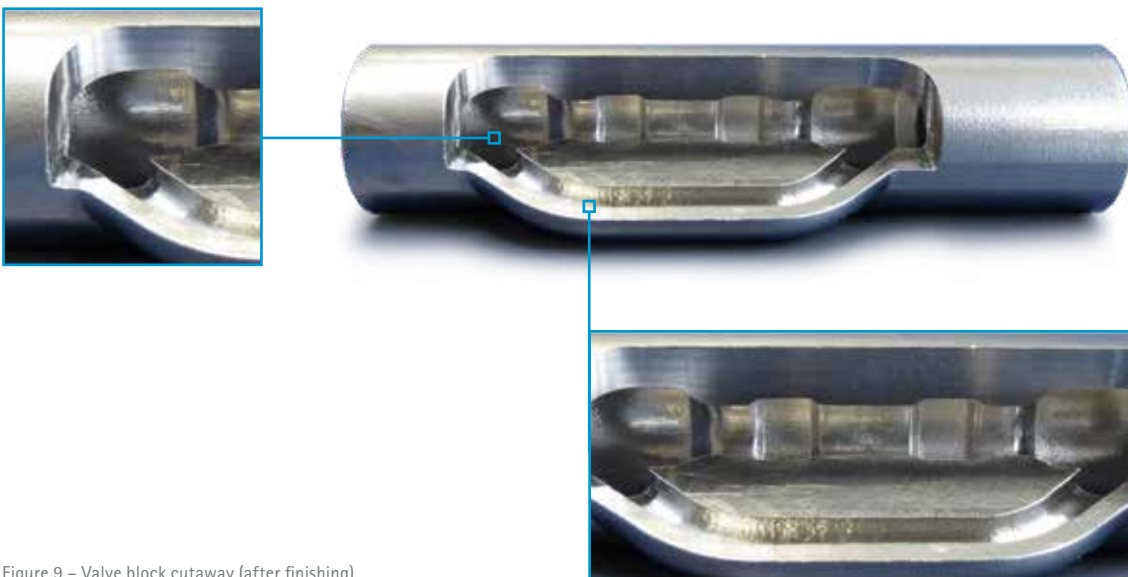

Figure 9 – Valve block cutaway (after finishing)



Figure 10 - COOLPULSE tooling main bore Et base



Figure 11 - COOLPULSE tooling showing cathode and part

Figure 10 shows the cathode which is required to finish the main bore of the valve block. **Figure 11** shows the part with the cathode parts required for the external surface enhancement.

For the side channel, where we could not apply COOLPULSE, we used a second process step with AFM. The following is a brief description of the tooling we used for AFM.

The side channel of the valve block was specifically designed for the special process requirements of AFM. The optimal flow conditions made it possible to maintain a sharp edge on the acute angle of the bore intersection to the main bore, and to achieve a uniform surface finish.

The AFM fixture consists of a bung which seals the center section of the main bore and directs the media through the side channel. After applying AFM for 20 minutes the expected surface quality inside the channel was achieved.



Figure 12 - Close-up of side channel finished with AFM

Fixture housing

Bung in main bore to guide media through side channel of the part for polishing

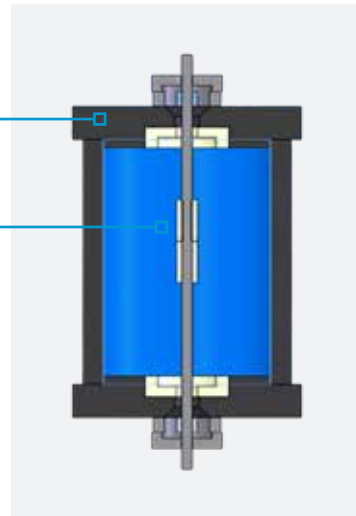

Figure 13 - AFM tooling

In **figure 13** you'll see a 3D model from the AFM fixture we used for processing the side channel without damaging the geometry which was already finished with COOLPULSE before. The bung in the middle ensures that the AFM media has to follow its way through the side channel for polishing it.

The overall finishing process took around 60 minutes to achieve a surface finish of $R_a < 2.5 \mu\text{m}$ on all surfaces, internally and externally.

Summary:

This case demonstrates the potential of combining both technologies, COOLPULSE and AFM. For internal and external surface finish on area with line-of-sight to a uniform surface finish we applied the COOLPULSE technology. Polishing of flow channels with intricate shapes was carried out with AFM. With the two finishing technologies it is possible unlocking freedom of design in 3D printing, even via the finishing process and to achieve repeatable finishing results at cost-effective cycle times.

Case 3

Surface test sample 17-4PH stainless steel

Application data:

- **Printing:** Four different building strategies for achieving four different surface qualities, superior, medium-superior, medium & poor surface roughness depending of the focus either "Productivity" or "Surface Quality".
- **Post-3D:** No post-treatment step
- **Task:** Highlight the effect of 3D print quality on surface enhancement and stock removal

The sample triangles (see figure 14) used for these trials were specifically designed to test the COOLPULSE finishing capabilities on certain types of typical surface topologies you'll find on 3D printed metal parts.



Figure 14 - Before / after image of the part.



The choice of the building strategy – focus either on "Productivity" or "Surface Quality" – has a massive impact on achieved surface roughness, build time and costs of the 3D printing process. Therefore, it is always about finding the right balance between cost-efficiency and quality of the product. To evaluate the influence on the COOLPULSE surface finishing process, we tested work-pieces printed with using four different printing

parameters focusing on different part qualities, superior, medium-superior, medium, and poor surface finish common when focusing on "Productivity". We used the same COOLPULSE process parameters and determined the relation between material removal and surface finish improvement at 50 µm intervals.

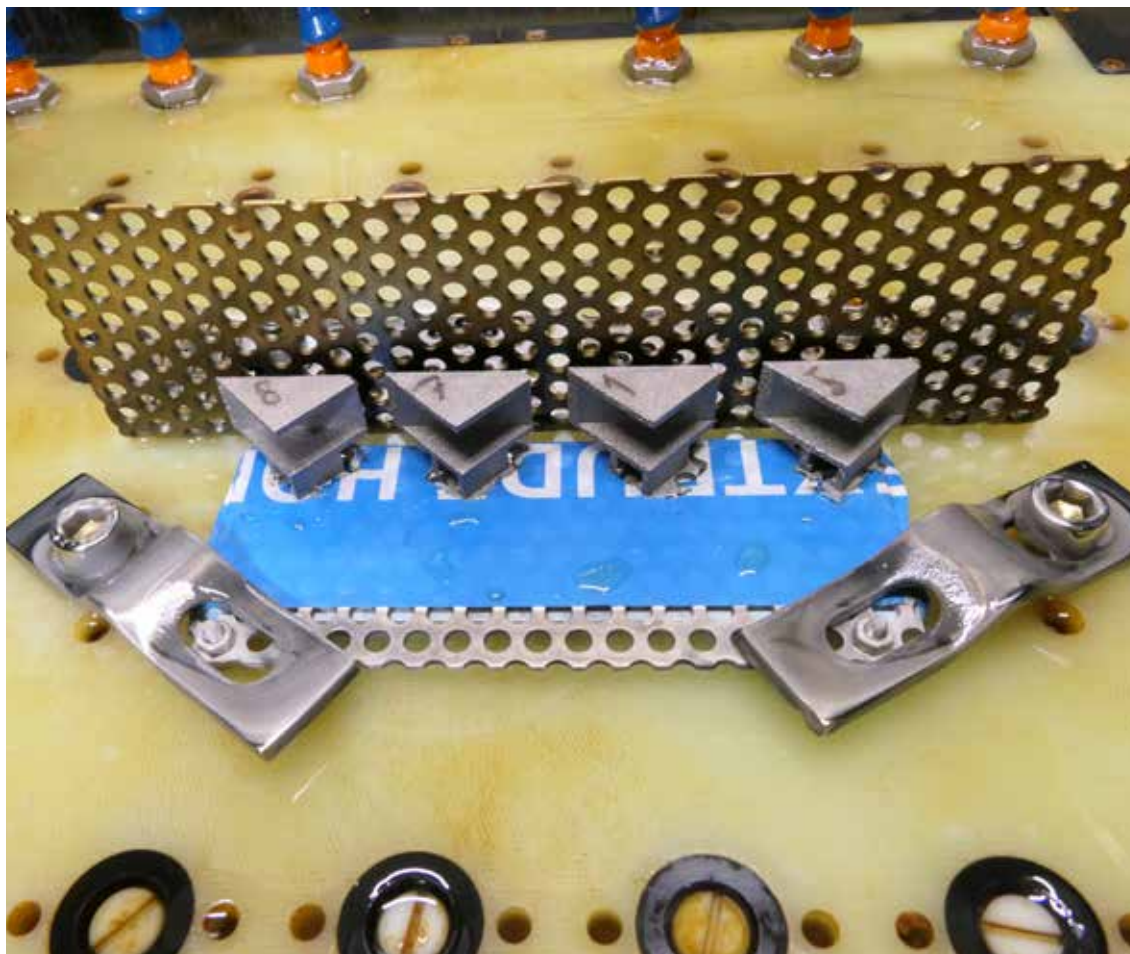

Figure 15 - Lab test tooling

Tooling:

For the test we used a simple lab tooling (see figure 15) which consists of a simple perforated metal sheet cathode, a workpiece holder accommodating four parts, and an anodic contact to the workpiece which was realized with a simple bracket.

Figure 16 shows four different samples before the COOLPULSE process was applied.

To determine the influence of the ALM process quality on printing time and finishing effort, which results in the overall process costs, we removed material in 50 μm increments and compared the surface finish on the up-skin area of the part.



Figure 16 - Different layer thicknesses

We found that, despite the differences in starting roughness, generated by the different additive manufacturing process strategy, the surface finish of the tested downskin area after removing 350 μm improved from a spread of almost 30 μm at the as printed surface from the SUPERIOR to POOR process to less than 4.5 μm . This means that, when selecting COOLPULSE as the finishing process, customers can reduce build time by using thicker layers when printing, and still achieve surface finish quality on downskin areas which meet requirements of functional surfaces.



Figure 17 - Measurement path (white dashed line)

For comparison, the graph (see figure 18) shows the material removal.

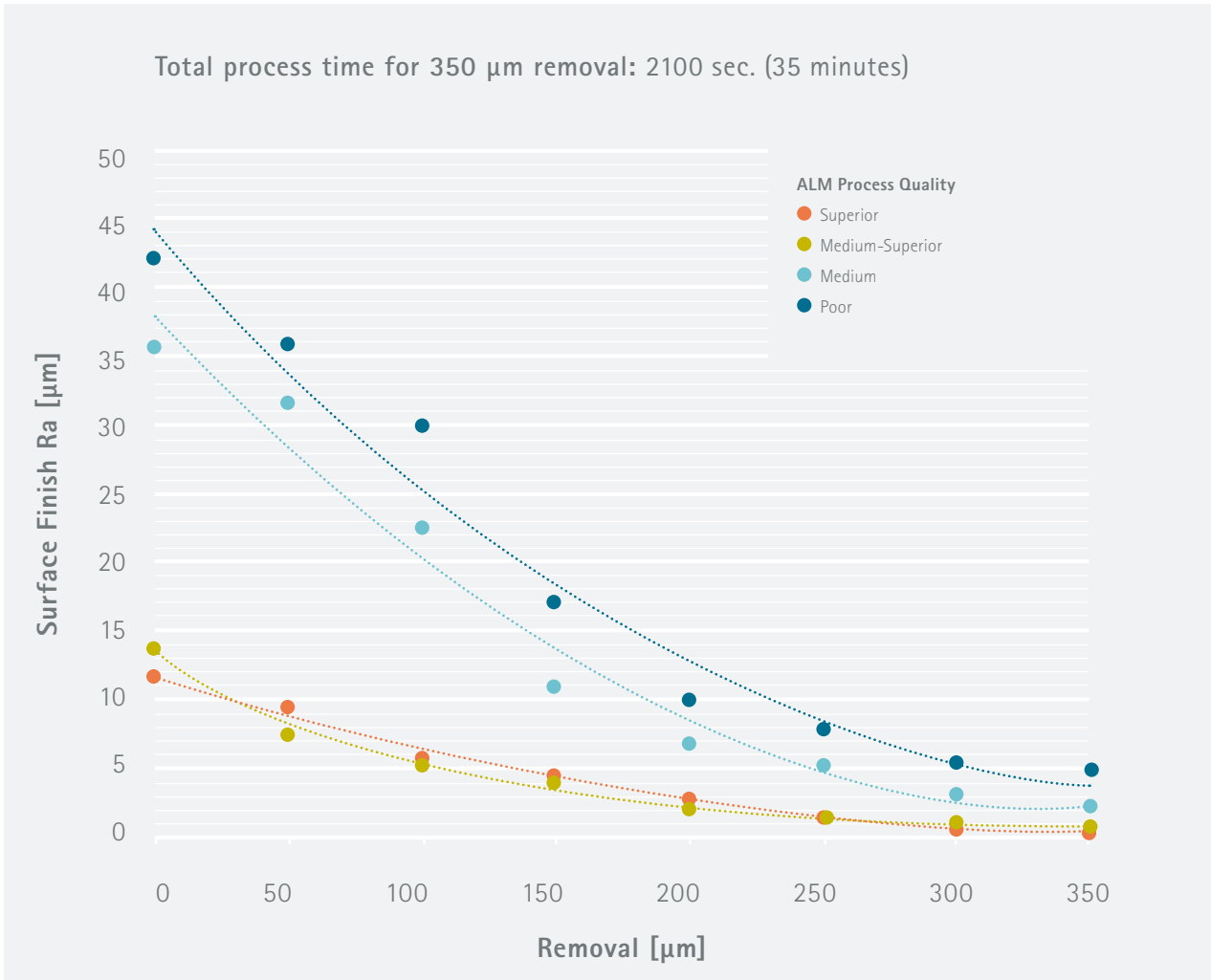

Figure 18 – Material Removal Graph

Processing time is independent from build process optimization:

Process time for 50 µm material removal:

300 sec. (5 minutes)

Total process time for 350 µm removal:

2100 sec. (35 minutes)

The trial was carried out starting from totally different surface roughness showing the achievable results after 350 μm of material removal, the graphs lines converge. Improvement on parts printed faster, achieving poor surface quality out of AM, can be explained by the COOLPULSE (ECM) principle – higher work rate, because of higher, thin and sharp peaks of the roughness profile which get dissolved easier and faster than with better Ra at the as print surface. After a certain material removal, the profiles start to converge.

Understanding the effect of the different as build surface quality of the 3D printed part and its correlation to the achievable surface finish with COOLPULSE will help us to determine the ratio between print quality and cost saving.

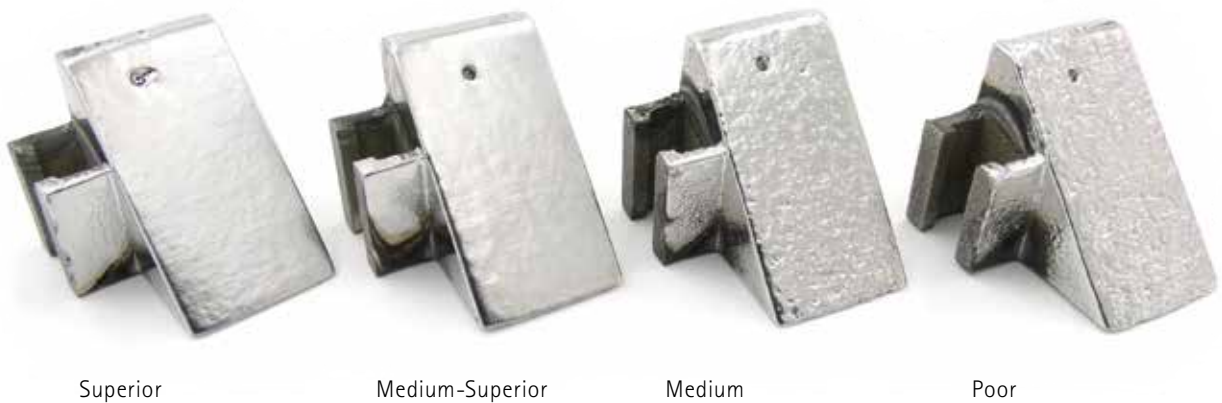

Figure 19 – Sample parts after COOLPULSE starting with different surface roughness after AM

Summary:

Figure 19 shows four various parts which were printed each in different quality, poor, medium, medium–superior and superior. The surface roughness was measured on the front ends of the parts, as shown in figure 17.

Conclusion:

With COOLPULSE and AFM there are two ground-breaking solutions in the finishing of additively manufactured parts. To achieve optimal results, it is crucial to consider both Additive Manufacturing and Surface Finishing jointly. In doing so, you (customer) will qualify more 3D applications and drastically reduce build time which, in turn, will generate cost savings. Extrude Hone and EOS are the perfect partners to support you in all your 3D application needs.



Robert Binder
Product Manager at
Extrude Hone

After finishing his study in industrial engineering Robert gathered detailed knowledge in project and product management during the different career steps he took. Finally with joining Extrude Hone in early 2017 he got in contact additive manufacturing on a daily base. As product manager for ECM technologies he and the EH team provide surface finishing solutions to the additive market.

Contact:
robert.binder@extrudehone.com



Lukas Fuchs
Business Development Manager
Turbomachinery

Lukas is responsible for Business Development at EOS for the turbomachinery industry. Lukas first encountered additive manufacturing in 2012 while studying laser physics. After receiving his master's degree, he specialized on the in-process monitoring of 3D metal printing as an Application Development Consultant for 3 years. Currently, he is working on enhancements of the AM technology, having a specific focus on efficient post-processing methods.

Contact:
lukas.fuchs@eos.info

EOS GmbH
Electro Optical Systems
Corporate Headquarters
Robert-Stirling-Ring 1
82152 Krailling/Munich
Germany

Phone +49 89 893 36-0
info@eos.info

www.eos.info

If you have any remarks
or comments,
please get in touch.